

RM Technology Platform

The European consolidation of
Rapid Manufacturing



www.rm-platform.com

RM Technology ? What is it ?

Rapid Manufacturing :

Computer automated
Additive manufacturing processes
to reliably construct
Functional parts
that are used directly as
Finished products or components

- "Small" production volumes or one-off products
- Without time nor money for specific tooling

RM Technology ? What is it ?



Figure 3 Micro fluidic sensor systems, RPMD (copyright microTEC)

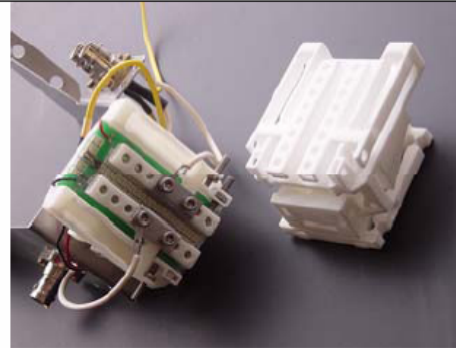

Figure 4 Adjustment mechanism, EOSINT laser sintering of PA (copyright TNO)



Figure 6 Tooth prostheses in CoCr alloy, solid phase laser sintering (copyright Phenix)



Figure 7 Fully dens cogwheel in SS, 35µ resolution xyz, Ink Jet Man. (copyright Fcubic)

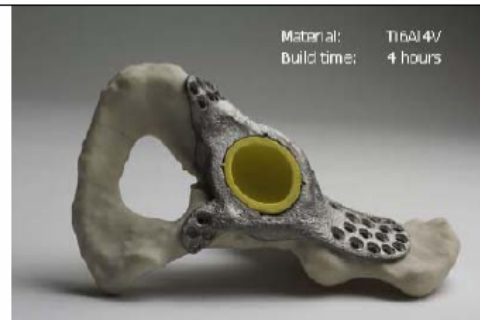
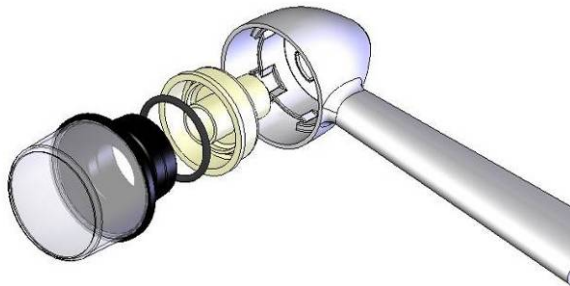
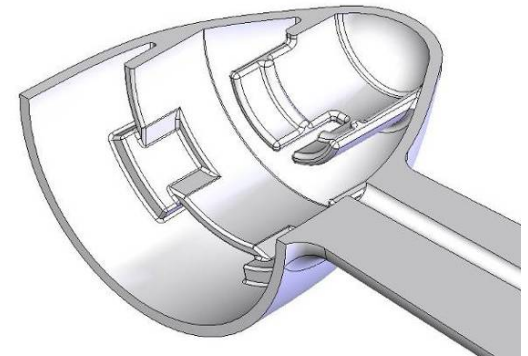

Figure 8 Customized Tri-flange Implant, Ti6Al4V, EBM (copyright Arcam)

RM Technology ? What is it ?



Direction
indicator



RM Technology Platform ? What is it ?

- A community of European stakeholders finding RM relevant to survive, grow and prosper

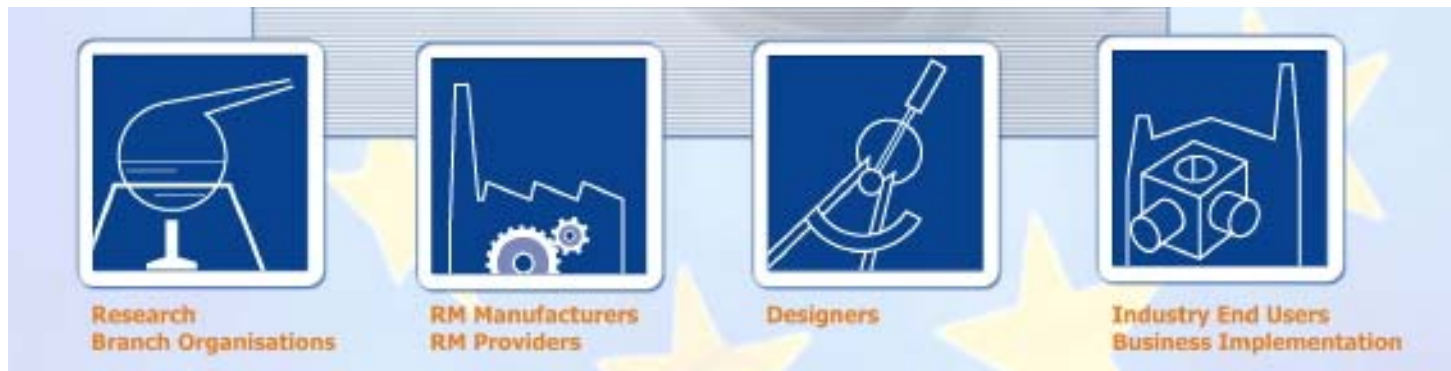

RM Technology Platform Objectives

- **A community of European stakeholders finding RM relevant to survive, grow and prosper**
 - 145 stakeholders
 - 92 from industry; 63%
 - 22 countries; great geographical balance
 - Status on November 2006 and expanding continuously.....

RM Technology Platform Objectives

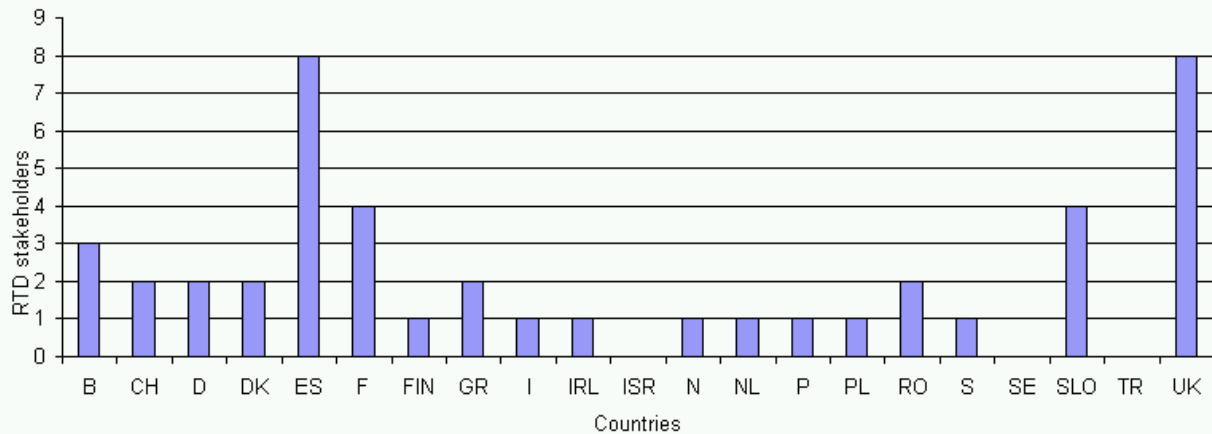
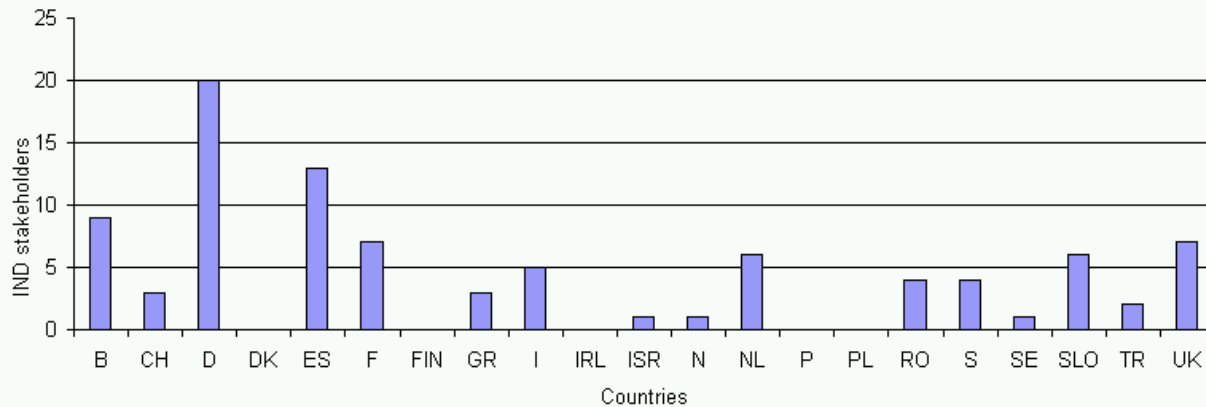

RM platform Objectives

- Consolidating on European level
- Achieving a coherent Vision on RM-future
- Defining the required research topics (SRA)
- Making a roadmap for RM
- Providing to EC for *possible* adoption in FP7
- Creating consortium with the BEST parties
- Initiate activities like projects; bilateral, (inter) national, funded or not

Potential impact

- **Mega-trends:**
 - Demand for individualization of products increases (mass customisation)
 - Products become more complex and life cycles shorten (pressure on cost and time-to-market)
 - Customer-oriented services as selling argument
 - Environmental issues get more attention
- **As a result:**
 - Mass production is moving outside Europe
 - Risk of tooling investment becomes show-stopper
 - Growth in niche markets and services

Potential impact

- **Solution: Rapid Manufacturing!**
 - No investment risk for tooling
 - Perfect for mass customisation
 - Minimum time-to-market
 - Minimum waste
 - Knowledge based rather than labour based
- **Still more expensive, just like every emerging technology**

Potential impact

- **Economic impact**
 - Reduction of cost and time, particularly for limited volumes
 - Risk management for investment and stock
 - Localized production minimizes logistics effort
 - Enhanced service dimension in business
 - Most importantly, new sales through niche, customized and new products

Potential impact

- **Social impact**
 - People can co-design products to their specific needs
 - Applications help the growing group of elderly & disabled people
 - Good for the environment; minimum energy consumption, reduced waste and pollution
 - Again: the *quality of life* is key term

Potential impact

- **EU policies are met**
 - Sustainability
 - Quality of life
 - Employment
 - Environment
- **Industry must come into action**
 - Top level support, integration in strategies
 - Cover complete supply chain
 - Integrate in market development & commercialisation
 - Create awareness, acceptance & adoption of RM

RM platform Pillars

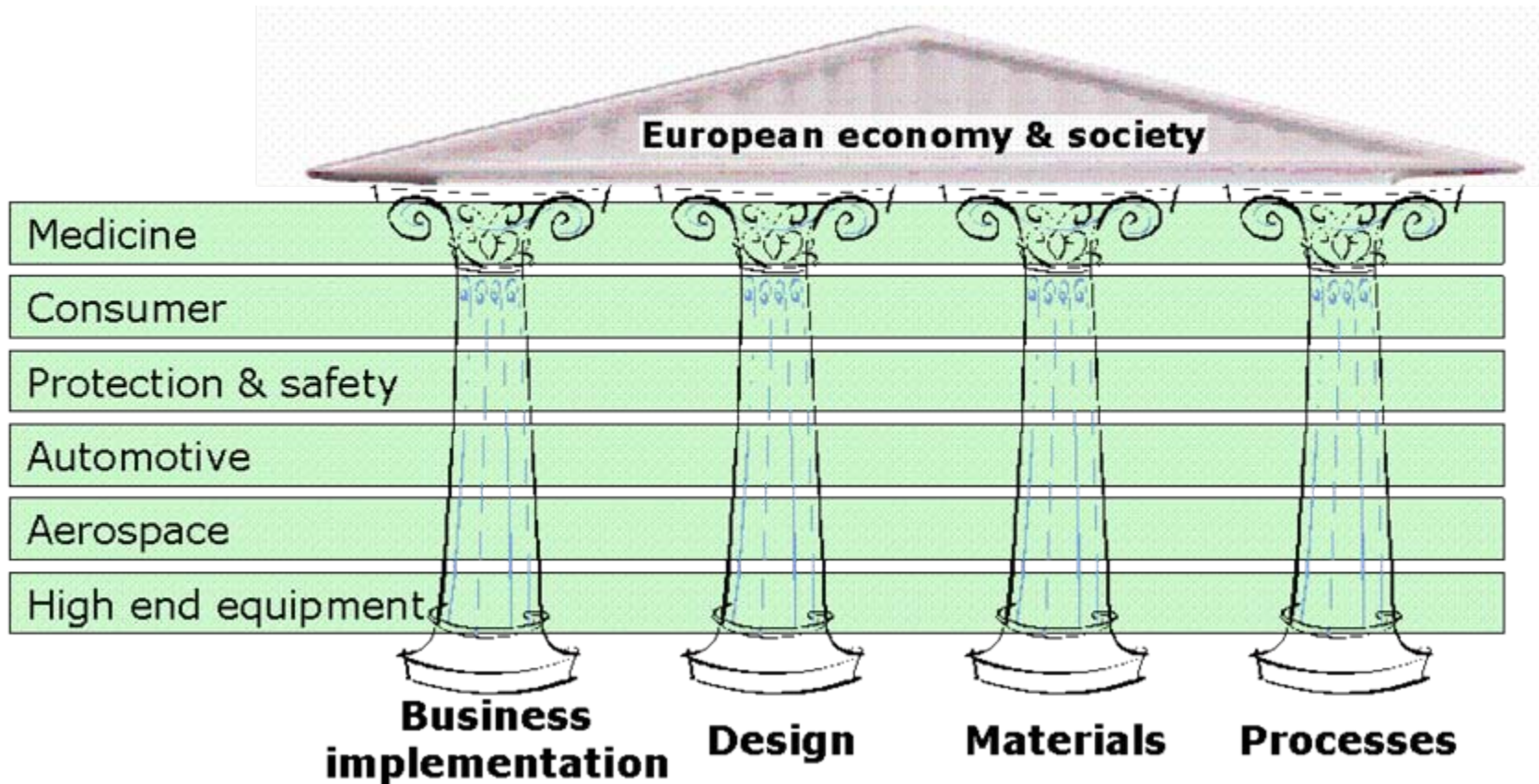

Business implementation

- Looking at the complete manufacturing picture rather than focussing solely at processes, material or design
- Mass production including resulting mass consumption has shaped our society
- RM does not fit within these standard thinking patterns and processes
- The total realisation chain will be affected

Business implementation

- **Vision on medium term**
 - **Costs of manufacturing**
 - **Implementation aspects**
 - **Education and skills programs for RM**

Business implementation

- **Vision on 2020**
 - RM beginning to become mainstream process
 - Centre on improvements to business processes, quality, the impact on local manufacturing & effects on skills & employment
 - Zero waste manufacturing
 - Quality standards
 - Stockless manufacturing
 - Location and distribution
 - Value Chain
 - Integration of RM with existing manufacturing
 - Fuzzy logic interface

Design

- **Design will change dramatically..**
 - Lead times / time-to-market gets shorter
 - # of product variants is rising
 - Complexity of design is rising
 - Responsibilities of the designer increase
 - Need support of VR-FEM & automated design
 - Unlimited geometrical freedom
 - Integration of functionalities by material variations
 - No assembly required

Design

- **Vision on medium term**

- Supporting software for macro textures & textile replacements in 3D format
- Experimental CAD system for Functionally Graded Materials (FGM)
- E-learning programs to fully exploit the opportunities for RM
- Integration of CAD, VR and FEM to support designers
- Experimental 3D Webcam for 3D low-level geometry scanning
- Experimental topological optimisation for automatic geometry optimisation
- Computational inspection of RM parts for First Time Right
- Cost price calculation comparing conventional with RM

Design

- **Vision on 2020**

- Free feature modelling CAD system
- Product specific CAD systems
- CAD for Functionally graded materials
- E-learning programs
- Integration of CAD, VR and FEM
- CAD systems with hybrid kernels
- 3D Webcam for 3D low-level geometry scanning
- Topological optimisation
- Multi objective & disciplinary optimisation
- Dummy proof design systems
- Computational inspection of RM parts
- Technologies for capturing user characteristics

Materials

- **Materials development is main driver for RM**
- **It is yet limiting factor for R&D**
- **Only few technologies to use per material**
- **Mainly few main players rule it all**

Materials

- **Vision on medium term**
 - New methods for substitution of classic materials
 - Prediction of the short and long term behaviour
 - Implementation of new energy sources
 - Investigation into the densification mechanisms
 - New purpose materials with unique selling point
 - Increase of industrial use of RM technologies
 - Integration into conventional production
 - Systematic approach to enable standardisation

Materials

- **Vision on 2020**

- **New generation of materials will be developed**
- **Supplementation of wide range stable materials**
- **Processes linked with unique material properties**
- **Operating system for the cost control of material's choice will be established**
- **Decision methods will assist planning, visualisation and simulation of RM material applications**

Processes

- **Specific advantages over conventional**
 - Any complex shape can be made
 - Costs independent from complexity (..)
 - Multi materials/components without assembly
 - Changes to geometry affected immediately
 - Especially interesting for limited volumes

Processes

- **Vision on medium term**
 - First introduced in several niche markets
 - Improvement into 100% solid material density
 - Economic manufacture (speed, cost)
 - Incorporation of nano-engineered materials
 - Use of high melting point alloys
 - Human spare parts in process
 - Sufficient and capable employment

Processes

- **Vision on 2020**

- Wider RM-use, complementary to mass production
- Cutting edge applications in medical area
- RM to be an appealing manufacturing technology
- Cutting edge applications with nano materials
- Large scale implementation of RM systems

RM platform + Belgium + FP7

- **Important and recognised stakeholders**

- Technical
- Scientific
- Industrial
- Organisational

LET'S DO IT !

www.Manufuture.be

- **Experienced support structures**

- **Geographic proximity**